



AN1310 HA/UA-PA-A-434 Module Datasheet V1.0

GPlus IoT Technology Inc.

No.12-2, Zhouzi St., Neihu Dist., Taipei City 114, Taiwan (R.O.C.)

AN1310 HA/UA-PA-A-434 Module Datasheet v1.0

Description

This AN1310HA/UA-PA Module is specifically designed for the long range applications. The CC1310 device, together with SKY66115-11 can support up to +20dBm TX power with high power efficiency, which addresses customers' needs for easy-to-use, long-range, low-power and low-cost solutions serving applications across the internet of Things.

The CC1310 device is the first part in a Sub-1-GHz family of cost-effective, ultralow power wireless MCUs. The CC1310 device combines a flexible, very low power RF transceiver with a powerful 48-MHz Cortex-M3 microcontroller in a platform supporting multiple physical layers and RF standards. A dedicated Radio Controller (Cortex-M0) handles low-level RF protocol commands that are stored in ROM or RAM, thus ensuring ultralow power and flexibility. The low-power consumption of the CC1310 device does not come at the expense of RF performance; the CC1310 device has excellent sensitivity and robustness (selectivity and blocking) performance.

The SKY66115-11 is a highly integrated front-end module designed for range extension and smart metering applications in the 433 to 510MHz range.

Block Diagram

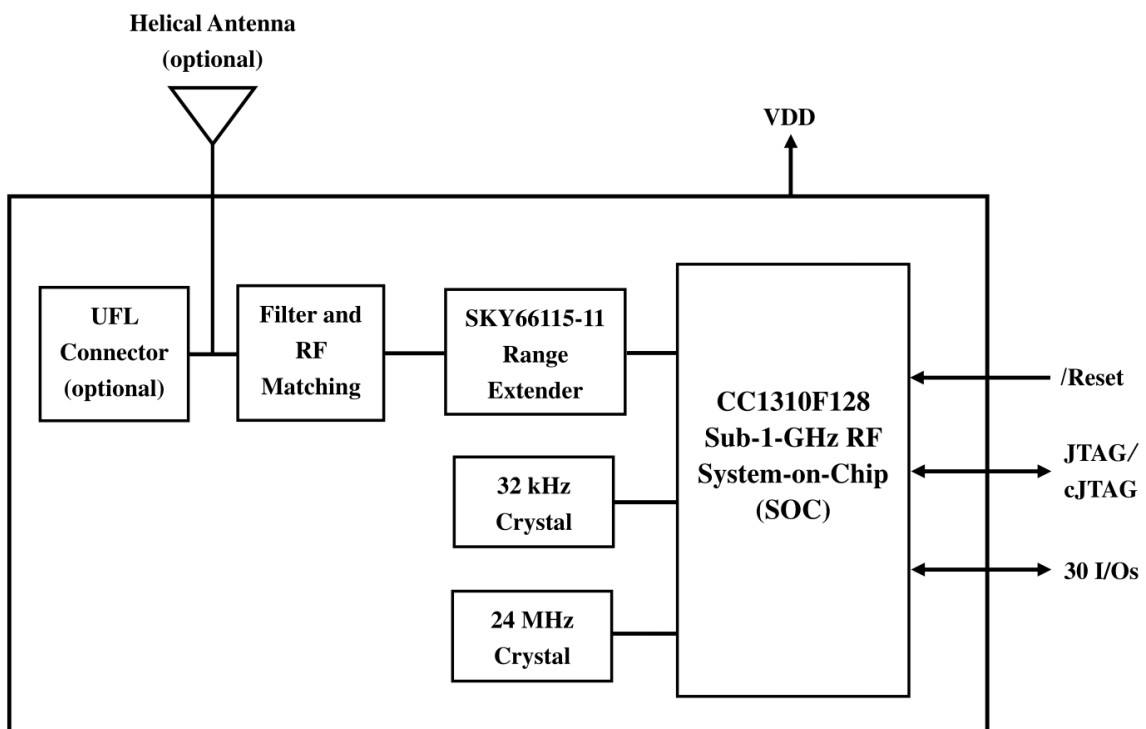

Specifications

Parameter	Min	Typical	Max	Unit
Operating Voltage	2.5	3.3	3.6	V
Operating Temperature	-30	-	+85	°C
Storage Temperature	-40	-	+125	°C
TX Power	-	+20	-	dBm
RX Sensitivity	-	-107.5	-	dBm

Controlling the SKY66115-11

CC1310-SKY66115-11 Interconnect

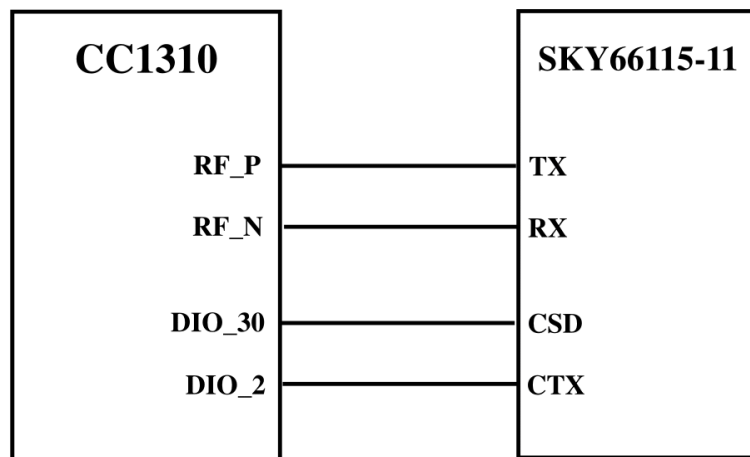

Control Logic for connecting the SKY66115-11 to a CC1310 device

Mode	CSD	CTX
Sleep Mode	0	X
Receive(RX) Mode	X	0
Transmit(TX) Mode	1	1

Module Information and Mechanical Drawing



AN1310HA-PA-A-XXX:

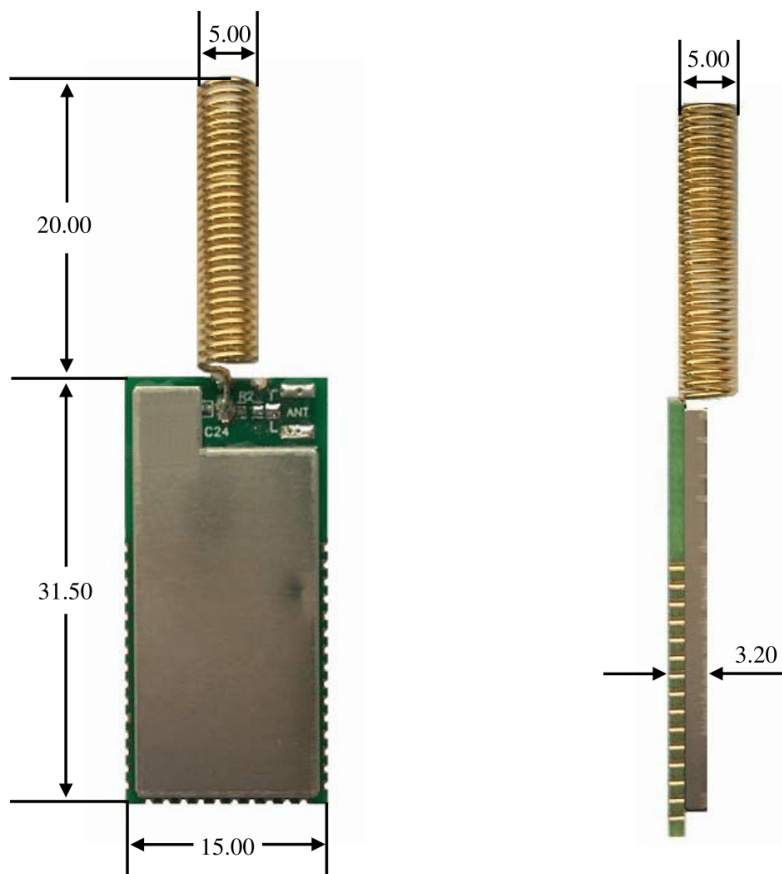

Unit: mm
Tolerance: ±0.2mm

AN1310UA-PA-A-XXX:

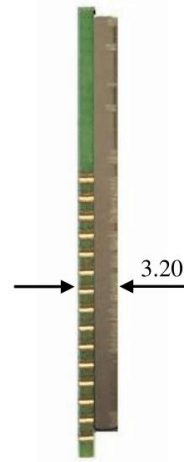
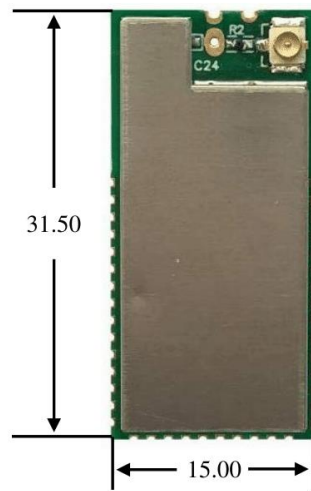

Unit: mm
Tolerance: $\pm 0.2\text{mm}$

Terminal Description

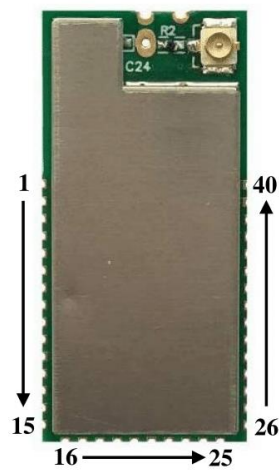

Pad Number	Name	Pin Type	Description
1	VDD_PA	Power	2.5V - 3.6V power supply for SKY6615-11
2	VDD_PA	Power	2.5V - 3.6V power supply for SKY6615-11

3	NC	-	-
4	DIO_1	Digital I/O	GPIO, Sensor Controller
5	DIO_2	Digital I/O	GPIO, Sensor Controller, CTX
6	DIO_3	Digital I/O	GPIO, Sensor Controller
7	DIO_4	Digital I/O	GPIO, Sensor Controller
8	DIO_5	Digital I/O	GPIO, Sensor Controller, High drive capability
9	DIO_6	Digital I/O	GPIO, Sensor Controller, High drive capability
10	DIO_7	Digital I/O	GPIO, Sensor Controller, High drive capability
11	GND	Ground Pin	Connect to GND
12	VDD	Power	2.5V to 3.6V main chip supply
13	DIO_8	Digital I/O	GPIO
14	DIO_9	Digital I/O	GPIO
15	DIO_10	Digital I/O	GPIO
16	DIO_11	Digital I/O	GPIO
17	DIO_12	Digital I/O	GPIO
18	DIO_13	Digital I/O	GPIO
19	DIO_14	Digital I/O	GPIO
20	DIO_15	Digital I/O	GPIO
21	JTAG_TMSC	Digital I/O	JTAG TMSC, High drive capability
22	JTAG_TCKC	Digital I/O	JTAG TCKC
23	DIO_16	Digital I/O	GPIO, JTAG_TDO, High drive capability
24	DIO_17	Digital I/O	GPIO, JTAG_TDI, High drive capability
25	DIO_18	Digital I/O	GPIO
26	DIO_19	Digital I/O	GPIO
27	DIO_20	Digital I/O	GPIO
28	DIO_21	Digital I/O	GPIO
29	DIO_22	Digital I/O	GPIO
30	RESET_N	Digital input	Reset, active-low, No internal pullup
31	DIO_23	Digital/Analog I/O	GPIO, Sensor Controller, Analog
32	DIO_24	Digital/Analog I/O	GPIO, Sensor Controller, Analog
33	DIO_25	Digital/Analog I/O	GPIO, Sensor Controller, Analog
34	DIO_26	Digital/Analog I/O	GPIO, Sensor Controller, Analog
35	DIO_27	Digital/Analog I/O	GPIO, Sensor Controller, Analog
36	DIO_28	Digital/Analog I/O	GPIO, Sensor Controller, Analog
37	DIO_29	Digital/Analog I/O	GPIO, Sensor Controller, Analog
38	DIO_30	Digital/Analog I/O	GPIO, Sensor Controller, Analog, CSD
39	GND	Ground Pin	Connect to GND
40	GND	Ground Pin	Connect to GND

Reference Schematics

VDD Wide Supply Voltage Range: 2.5V to 3.6V

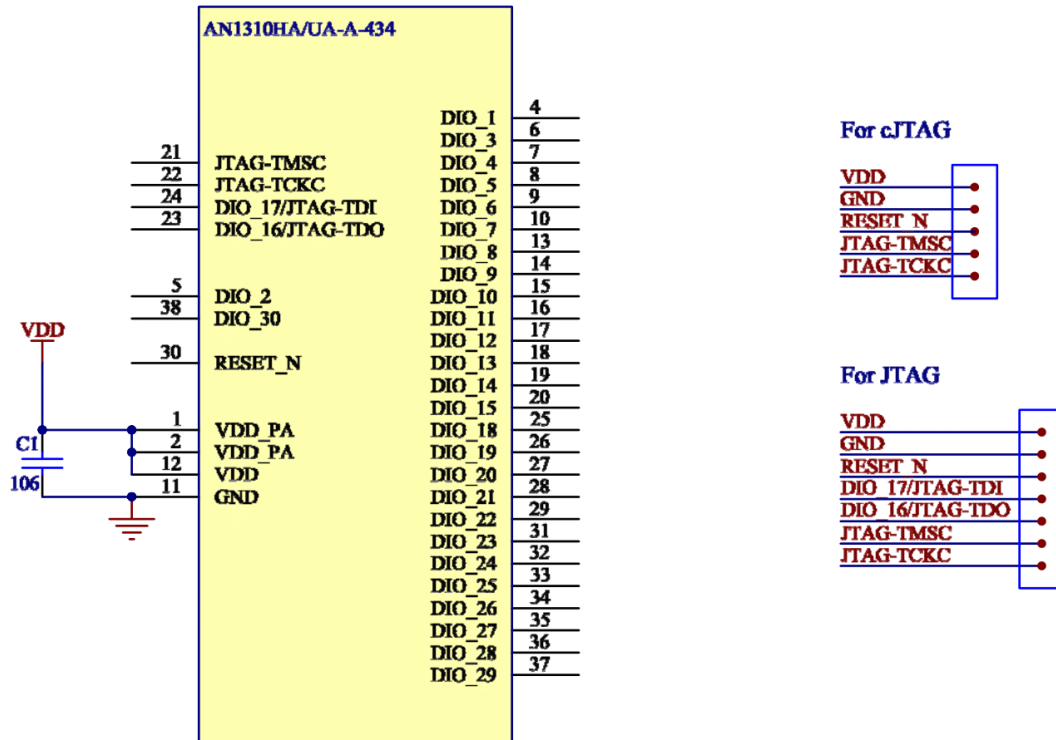

Recommended PCB Layout for Package

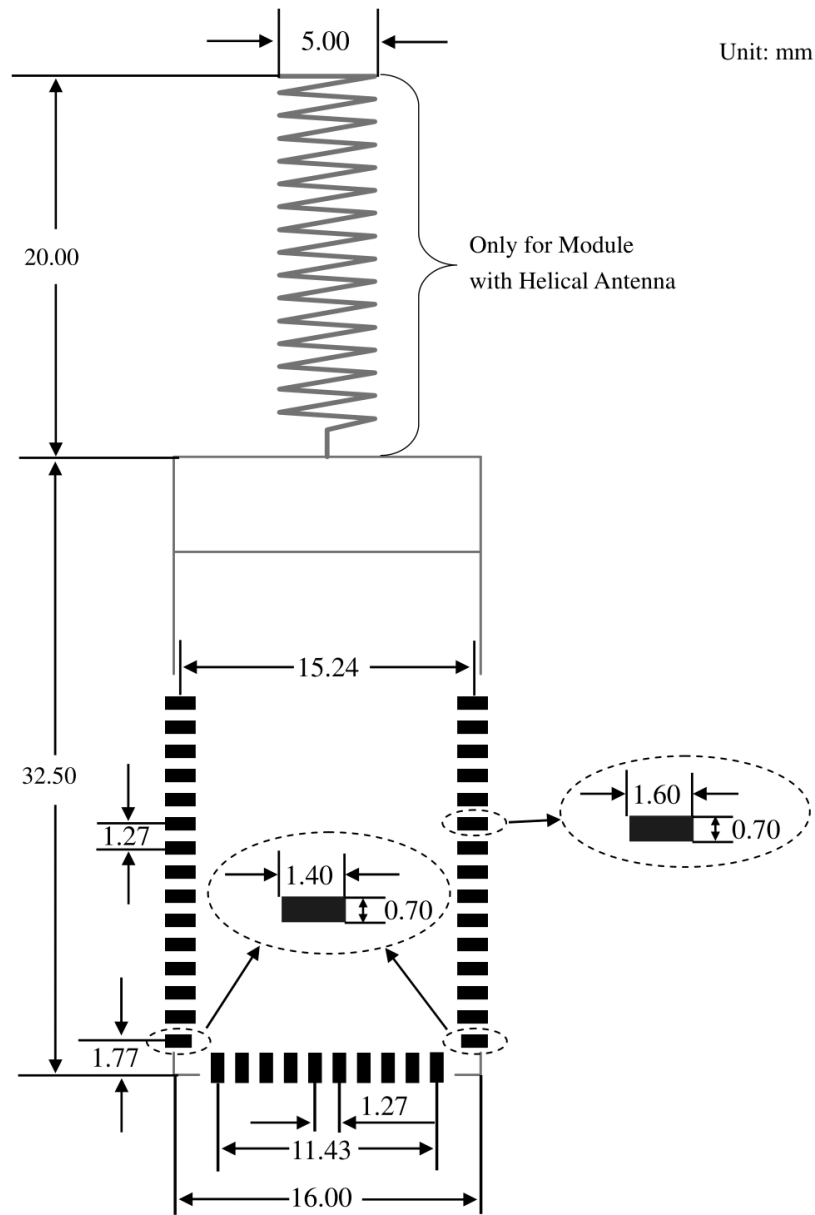

Recommended Reflow Profile for Lead Free Solder

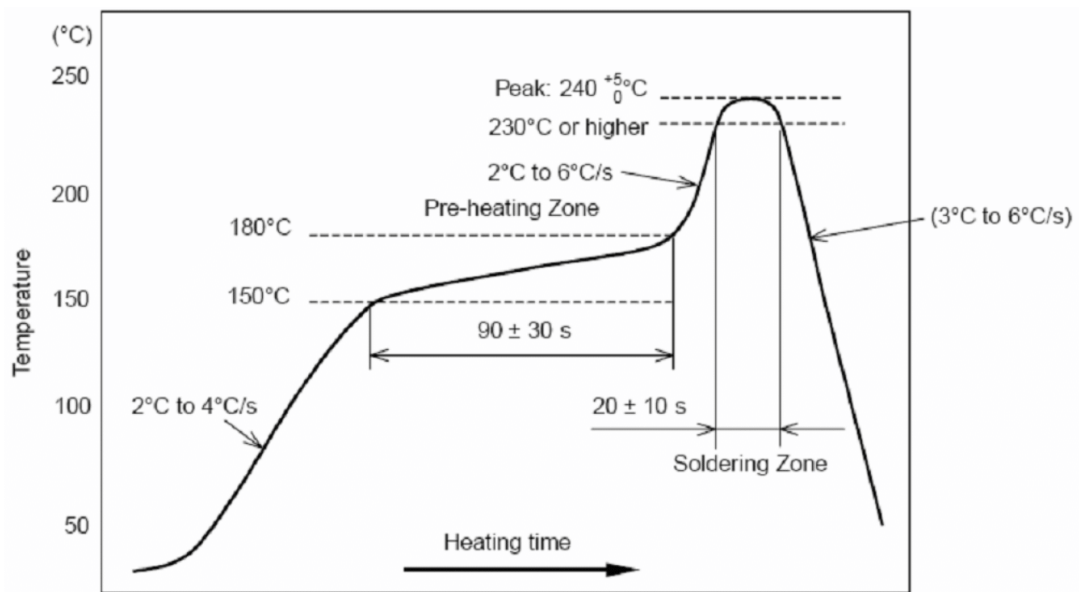

Contact details

For more information, please send email to us. Email:

jp.chen@gplusiot.net

jerry.liu@gplusiot.net